

HIGH VOLTAGE SWITCHING DIODE

Dimensions SOD-323

- We declare that the material of product compliance with RoHS requirements.
- S- Prefix for Automotive and Other Applications Requiring Unique Site and Control Change Requirements; AEC-Q101 Qualified and PPAP Capable.



ORDERING INFORMATION

Device	Marking	Shipping
LBAS21HT1G	JS	3000/Tape&Reel
LBAS21HT3G	JS	10000/Tape&Reel

Pin Configuration



MAXIMUM RATINGS

Rating	Symbol	Value	Unit
Continuous Reverse Voltage	V_R	250	Vdc
Peak Forward Current	I_F	200	mAdc
Peak Forward Surge Current	$I_{FM(surge)}$	625	mAdc

THERMAL CHARACTERISTICS

Characteristic	Symbol	Max	Unit
Total Device Dissipation FR-5 Board,* $T_A = 25^\circ\text{C}$ Derate above 25°C	P_D	200	mW
Thermal Resistance Junction to Ambient	$R_{\theta JA}$	635	$^\circ\text{C/W}$
Junction and Storage Temperature Range	T_J, T_{stg}	-55 to+150	$^\circ\text{C}$

*FR-5 Minimum Pad

ELECTRICAL CHARACTERISTICS ($T_A = 25^\circ\text{C}$ unless otherwise noted)

Characteristic	Symbol	Min	Max	Unit
----------------	--------	-----	-----	------

OFF CHARACTERISTICS

Reverse Voltage Leakage Current ($V_R = 200$ Vdc) ($V_R = 200$ Vdc, $T_J = 150^\circ\text{C}$)	I_R	-	0.1	μAdc	
Reverse Breakdown Voltage ($I_{BR} = 100$ μAdc)	$V_{(BR)}$	250	-	Vdc	
Forward Voltage ($I_F = 100$ mAdc) ($I_F = 200$ mAdc)	V_F	-	1000 1250	mV	
Forward resistance	r_f	$I_F = 1\text{mA}$ $f = 100$ MHz)	15	20	Ω
		$I_F = 10\text{mA}$ $f = 100$ MHz)	2.5	3.8	
		$I_F = 100\text{mA}$ $f = 100$ MHz)	1.1	1.35	
Diode Capacitance ($V_R = 0$, $f = 1.0$ MHz)	C_D	-	5.0	pF	
Reverse Recovery Time ($I_F = I_R = 30$ mAdc, $R_L = 100$ Ω)	t_{rr}	-	50	ns	

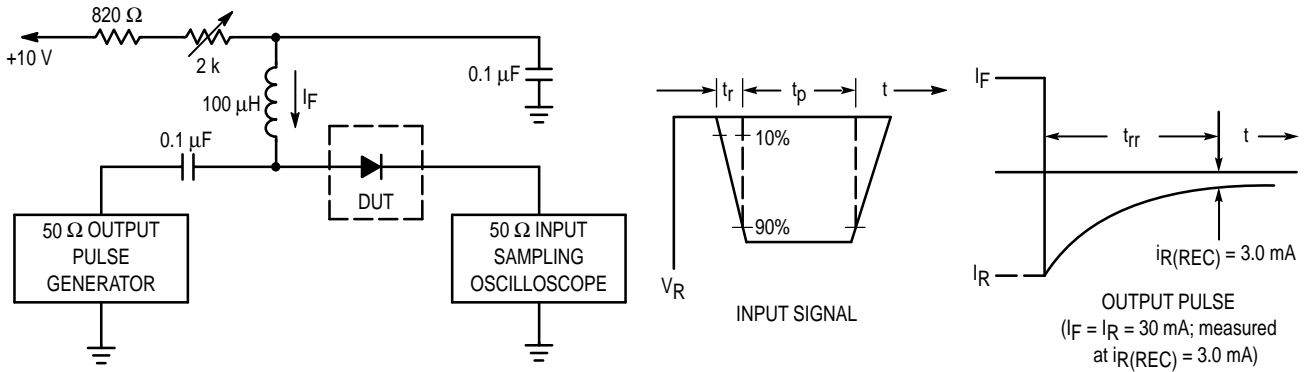

Figure 1. Recovery Time Equivalent Test Circuit

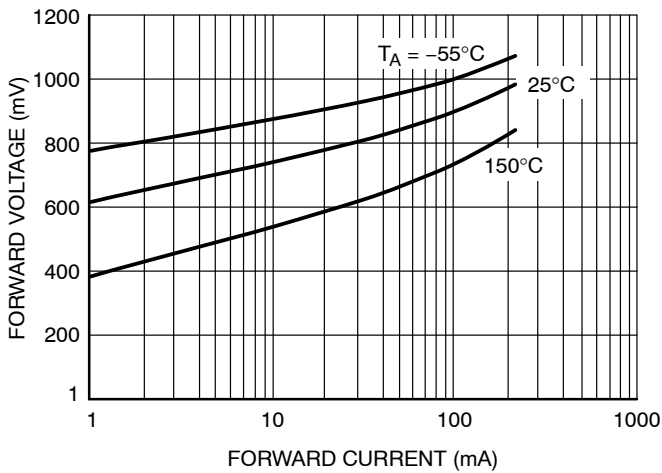

Figure 2. Forward Voltage

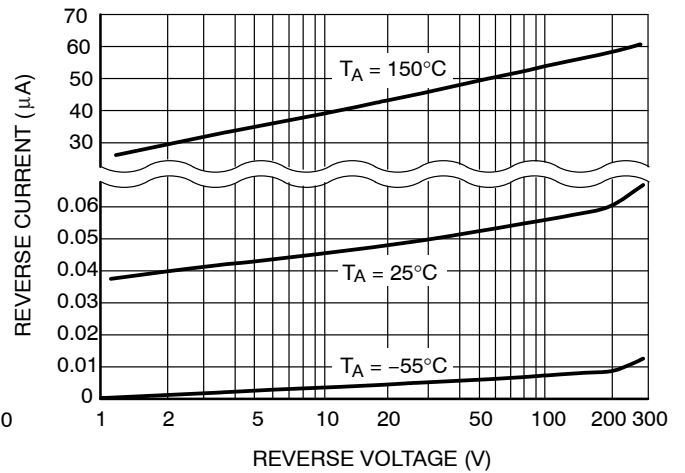
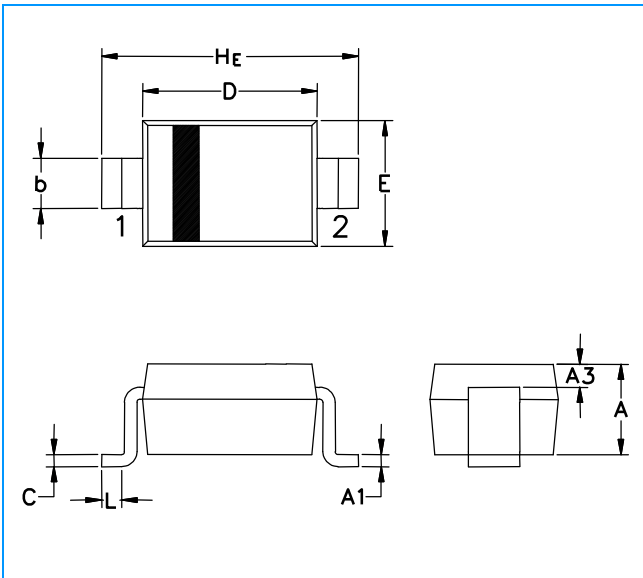

Figure 3. Reverse Leakage

SOD-323 Package Outline & Dimensions



Symbol	Millimeters			Inches		
	Min.	Nom.	Max.	Min.	Nom.	Max.
A	0.80	0.90	1.00	0.031	0.035	0.040
A1	0.00	0.05	0.10	0.000	0.002	0.004
A3	0.15 REF			0.006 REF		
b	0.25	0.32	0.40	0.010	0.012	0.016
C	0.089	0.12	0.177	0.003	0.005	0.007
D	1.60	1.70	1.80	0.062	0.066	0.070
E	1.15	1.25	1.35	0.045	0.049	0.053
L	0.08			0.003		
H_E	2.30	2.50	2.70	0.090	0.098	0.105

Soldering Footprint

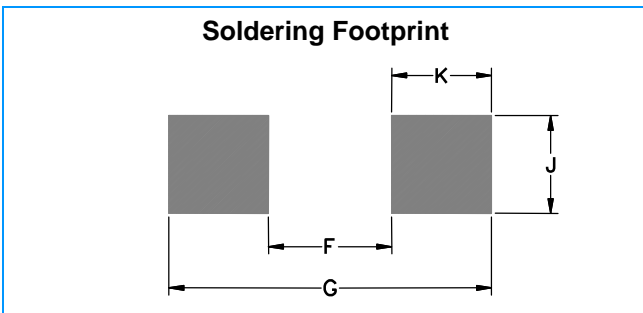

Symbol	Millimeters	Inches
F	1.60	0.063
G	2.85	0.112
J	0.83	0.033
K	0.63	0.025