

### Features

- Ultra low leakage: nA level
- Operating voltage: 5V
- Low clamping voltage
- Up to 4 data lines and one power line protects
- Complies with following standards:
  - IEC 61000-4-2 (ESD) immunity test
    - Air discharge:  $\pm 20\text{kV}$
    - Contact discharge:  $\pm 20\text{kV}$
  - IEC61000-4-4 (EFT) 40A (5/50ns)
  - IEC61000-4-5 (Lightning) 5A/17A (8/20 $\mu\text{s}$ )
- RoHS Compliant

### Dimensions SOT-26

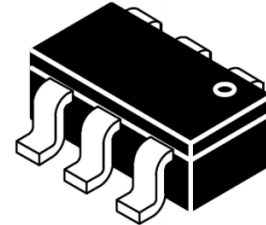

### Applications

- USB 2.0 power and data line
- Set-top box and digital TV
- Digital video interface (DVI)
- Notebook Computers
- SIM Ports
- 10/100/1000 Ethernet

### Pin Configuration

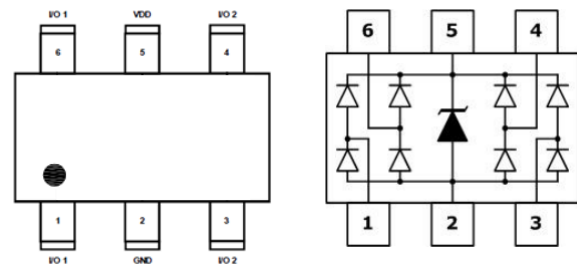

### Mechanical Characteristics

- Package: SOT-26
- Lead Finish: Lead Free
- UL Flammability Classification Rating 94V-0
- Quantity Per Reel: 3,000pcs
- Reel Size: 7inch
- Device Marking: V05

### Absolute Maximum Ratings (Tamb=25°C unless otherwise specified)

| Parameter   | Symbol                | Value       | Unit |
|---|-----------------------|-------------|------|
| Peak Pulse Power (8/20 $\mu\text{s}$ , I/O-GND)   | Ppk                   | 60          | W    |
| Peak Pulse Power (8/20 $\mu\text{s}$ , Vcc-GND)   | Ppk                   | 300         | W    |
| Peak Pulse Current (8/20 $\mu\text{s}$ , I/O-GND) | IPP                   | 5           | A    |
| Peak Pulse Current (8/20 $\mu\text{s}$ , Vcc-GND) | IPP                   | 17          | A    |
| ESD per IEC 61000-4-2 (Air)                       | V <sub>ESD, VDD</sub> | $\pm 20$    | kV   |
| ESD per IEC 61000-4-2 (Contact)                   | V <sub>ESD, I/O</sub> | $\pm 20$    | kV   |
| Operating Temperature Range                       | TJ                    | -55 to +125 | °C   |
| Storage Temperature Range                         | Tstg                  | -55 to +150 | °C   |

## Electrical Characteristics (TA=25°C unless otherwise specified)

| Parameter                 | Symbol    | Test Condition   | Min | Typ  | Max  | Unit          |
|---------------------------|-----------|--|-----|------|------|---------------|
| Reverse Working Voltage   | $V_{RWM}$ | Pin 5 to GND, I/O-GND  |     |      | 5.0  | V             |
| Breakdown Voltage         | $V_{BR}$  | $I_T = 1\text{mA}$ (Pin 5 to GND, I/O-GND)                           | 6.0 | 7.5  | 8.5  | V             |
| Reverse Leakage Current   | $I_R$     | $V_{RWM} = 5.0\text{V}$  |     |      | 0.5  | $\mu\text{A}$ |
| Forward Breakdown Voltage | $V_F$     | $I_F = 15\text{mA}$ , GND to Pin 5/IO                                |     | 0.8  | 1.0  | V             |
| Clamping Voltage          | $V_C$     | $I_{PP} = 5\text{A}$ (8 x 20 $\mu\text{s}$ pulse, I/O to GND)        |     | 14.0 | 15.0 | V             |
| Clamping Voltage          | $V_C$     | $I_{PP} = 17\text{A}$ (8 x 20 $\mu\text{s}$ pulse, Pin 5 to GND)     |     | 16.0 | 18.0 | V             |
| Junction Capacitance      | $C_J$     | $V_{pin5} = 5\text{V}$ , I/O=0V,<br>$f = 1\text{MHz}$ , I/O-GND      |     | 0.6  | 0.7  | pF            |
| Junction Capacitance      | $C_J$     | $V_{pin5} = 5\text{V}$ , I/O=0V,<br>$f = 1\text{MHz}$ , I/O-I/O pins |     | 0.3  | 0.4  | pF            |

## Typical Performance Characteristics (TA=25°C unless otherwise specified)

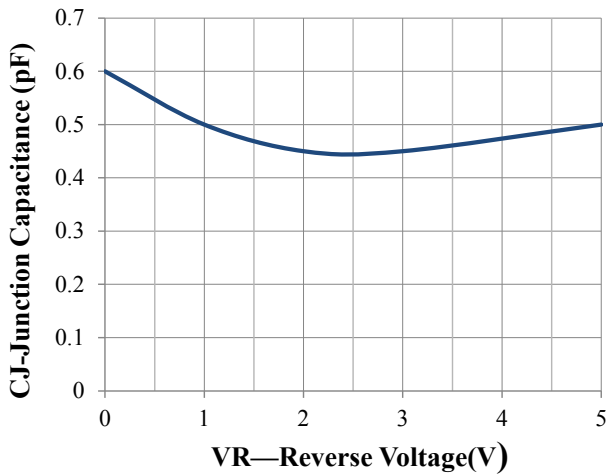

Junction Capacitance vs. Reverse Voltage

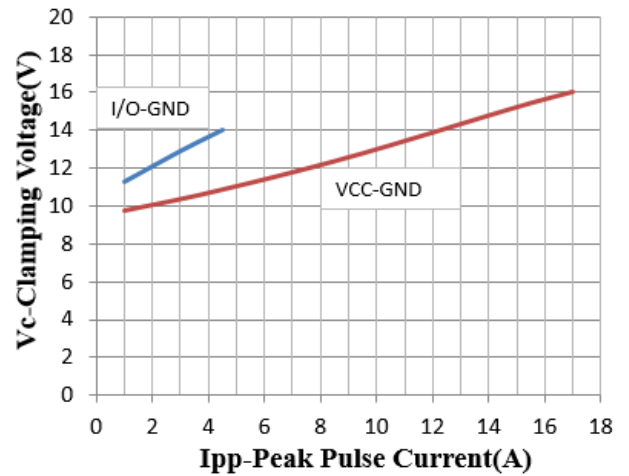

Clamping Voltage vs. Peak Pulse Current

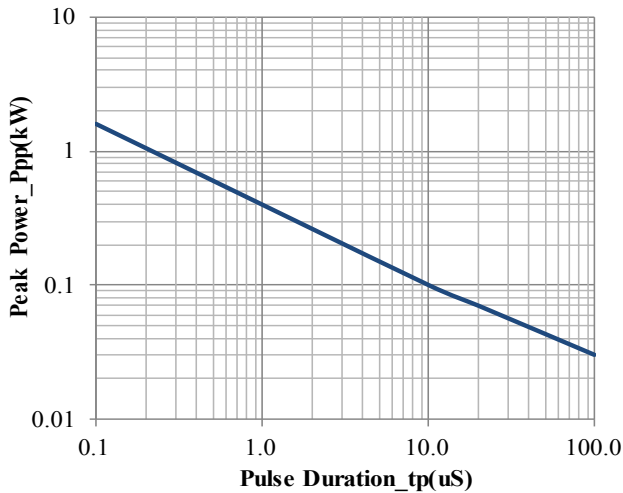

Peak Pulse Power vs. Pulse Time

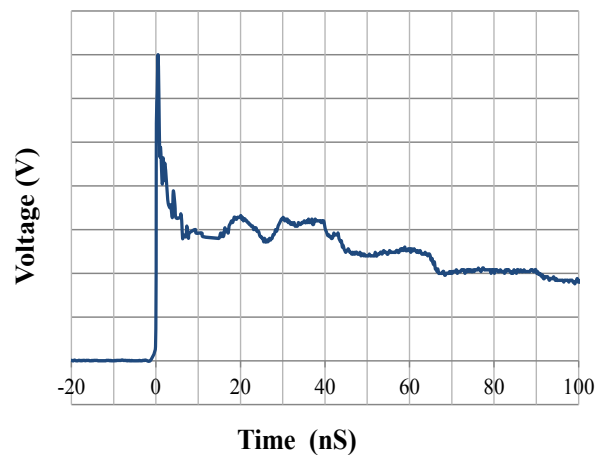

IEC61000-4-2 Pulse Waveform

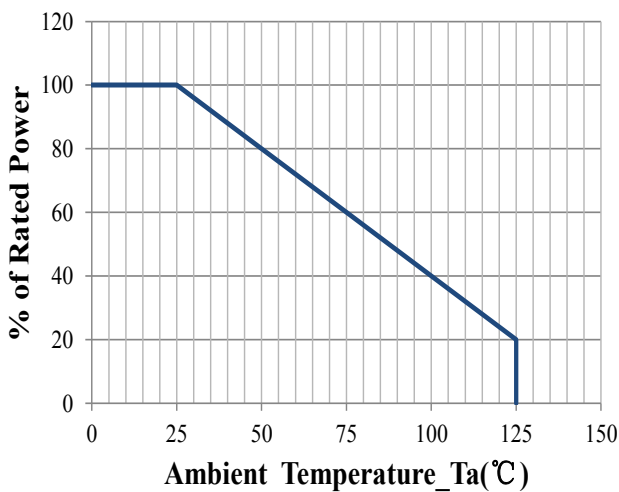

Power Derating Curve

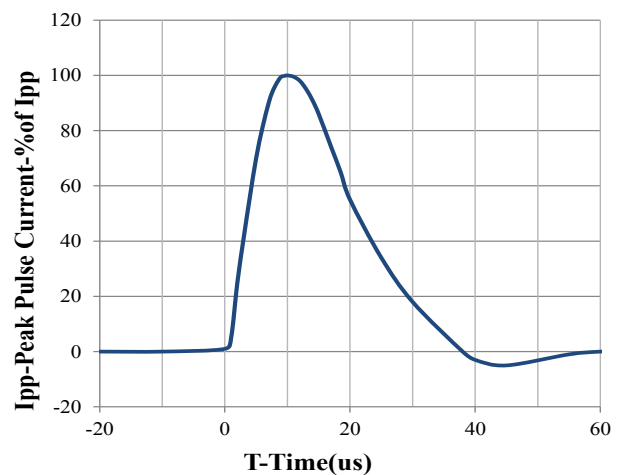

8 X 20us Pulse Waveform

## Applications Information

**Figure 1. Data Line and Power Supply Protection Using  $V_{CC}$  as reference**

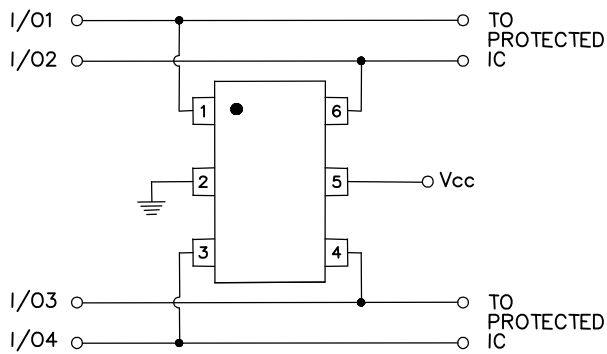

**Figure 2. Data Line Protection with Bias and Power Supply Isolation Resistor**

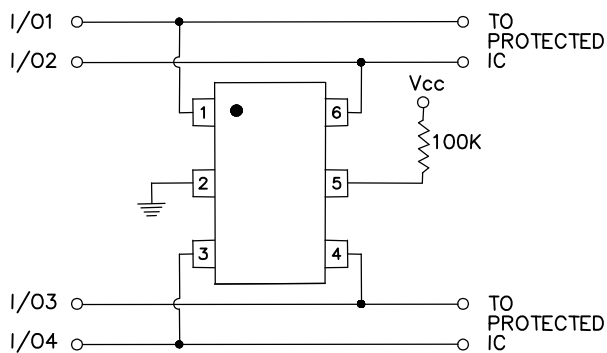

**Figure 3. Data Line Protection Using Internal TVS Diode as Reference**

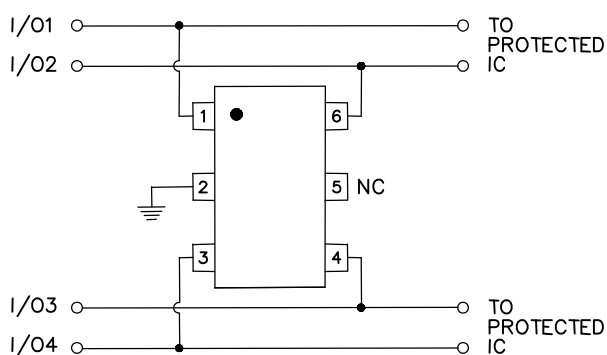

### Device Connection Options for Protection of Four High-Speed Data Lines

The TPD4E001DBVR is designed to protect four data lines from transient over-voltages by clamping them to a fixed reference. When the voltage on the protected line exceeds the reference voltage (plus diode  $V_F$ ) the steering diodes are forward biased, conducting the transient current away from the sensitive circuitry. Data lines are connected at pins 1, 3, 4 and 6. The negative reference (REF1) is connected at pin 2. This pin should be connected directly to a ground plane on the board for best results. The path length is kept as short as possible to minimize parasitic inductance. The positive reference (REF2) is connected at pin 5. The options for connecting the positive reference are as follows:

1. To protect data lines and the power line, connect pin 5 directly to the positive supply rail ( $V_{CC}$ ). In this configuration the data lines are referenced to the supply voltage. The internal TVS diode prevents over-voltage on the supply rail (See Figure1).
2. The TPD4E001DBVR can be isolated from the power supply by adding a series resistor between pin 5 and  $V_{CC}$ . A value of  $100k\Omega$  is recommended. The internal TVS and steering diodes remain biased, providing the advantage of lower capacitance (See Figure2).
3. In applications where no positive supply reference is available, or complete supply isolation is desired, the internal TVS may be used as the reference. In this case, pin 5 is not connected. The steering diodes will begin to conduct when the voltage on the protected line exceeds the working voltage of the TVS (plus one diode drop) (See Figure3).

## Applications Information (Continue)

**Figure 4. Video Interface Protection**

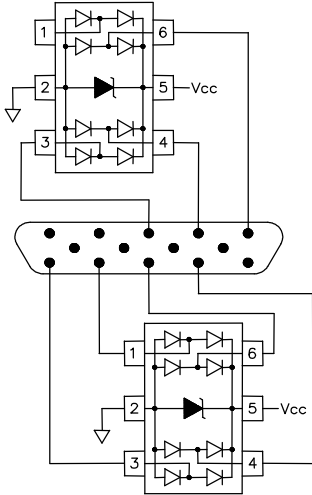

**Figure 5 - Dual USB Port Protection**

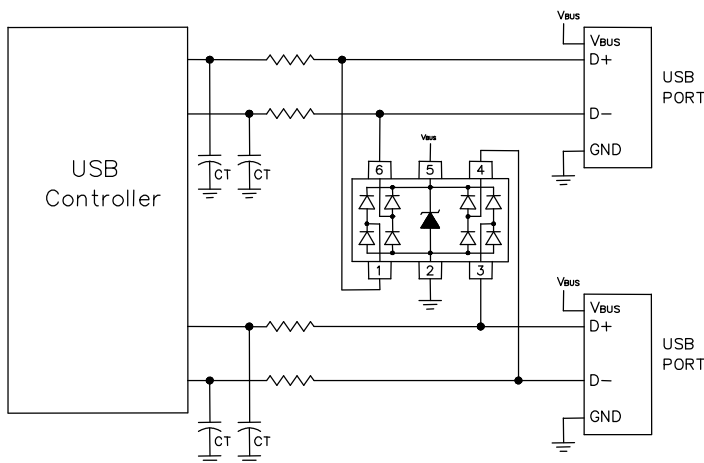

**Figure 6 - SIM Port**

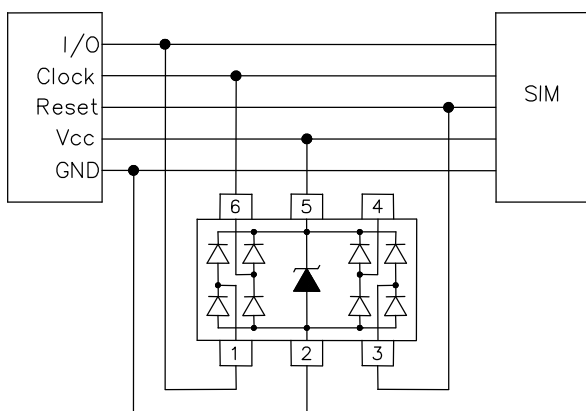

### Video Interface Protection

Video interfaces are susceptible to transient voltages resulting from electrostatic discharge (ESD) and “hot plugging” cables. If left unprotected, the video interface IC may be damaged or even destroyed. Protecting a high-speed video port presents some unique challenges. First, any added protection device must have extremely low capacitance and low leakage current so that the integrity of the video signal is not compromised. Second, the protection component must be able to absorb high voltage transients without damage or degradation. As a minimum, the device should be rated to handle ESD voltages per IEC61000-4-2, level 4 ( $\pm 15\text{kV}$  air,  $\pm 8\text{kV}$  contact). The clamping voltage of the device (when conducting high current ESD pulses) must be sufficiently low enough to protect the sensitive CMOS IC. If the clamping voltage is too high, the “protected” device may latch-up or be destroyed. Finally, the device must take up a relatively small amount of board space, particularly in portable applications such as notebooks and handhelds. The TPD4E001DBVR is designed to meet or exceed all of the above criteria. A typical video interface protection circuit is shown in Figure 4. All exposed lines are protected including R, G, B, H-Sync, V-Sync, and the ID lines for plug and play monitors.

### Universal Serial Bus ESD Protection

The TPD4E001DBVR may also be used to protect the USB ports on monitors, computers, peripherals or portable systems. Each device will protect up to two USB ports (Figure5). When the voltage on the data lines exceed the bus voltage (plus one diode drop), the internal rectifiers are forward biased conducting the transient current away from the protected controller chip. The TVS diode directs the surge to ground. The TVS diode also acts to suppress ESD strikes directly on the voltage bus. Thus, both power and data pins are protected with a single device.

## Applications Information (Continue)

### DVI Protection

The small geometry of a typical digital-visual interface (DVI) graphic chip will make it more susceptible to electrostatic discharges (ESD) and cable discharge events (CDE). Transient protection of a DVI port can be challenging. Digital-visual interfaces can often transmit and receive at a rate equal to or above 1Gbps. The high-speed data transmission requires the protection device to have low capacitance to maintain signal integrity and low clamping voltage to reduce stress on the protected IC. The TPD4E001DBVR has a low typical insertion loss of <math><0.4\text{dB}</math> at 1GHz (I/O to ground) to ensure signal integrity and can protect the DVI interface to the 8kV contact and 15kV air ESD per IEC 61000-4-2 and CDE.

Figure 7 shows how to design the TPD4E001DBVR into the DVI circuit on a flat panel display and a PC graphic card. The TPD4E001DBVR is configured to provide common mode and differential mode protection. The internal TVS of the TPD4E001DBVR acts as a 5 volt reference. The power pin of the DVI circuit does not come out through the connector and is not subjected to external ESD pulse; therefore, pin 5 should be left unconnected. Connecting pin 5 to Vcc of the DVI circuit may result in damage to the chip from ESD current.

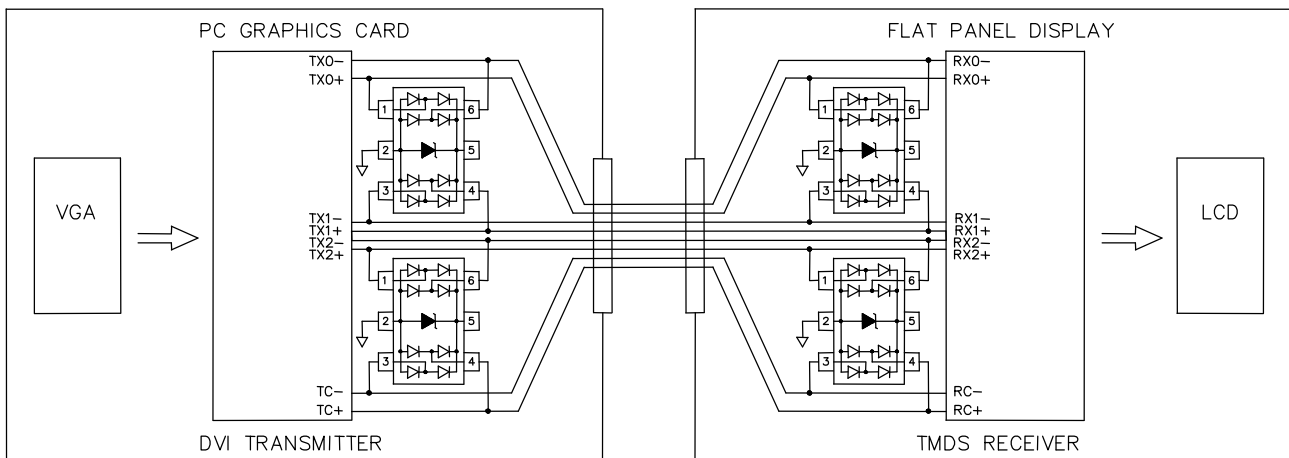

**Figure 7 . Digital Video Interface (DVI) Protection**

### 10/100 ETHERNET PROTECTION

Ethernet ICs are vulnerable to damage from electro-static discharge (ESD). The internal protection in the PHY chip, if any, often is not enough due to the high energy of the discharges specified by IEC 61000-4-2. If the discharge is catastrophic, it will destroy the protected IC. If it is less severe, it will cause latent failures that are very difficult to find.

10/100 Ethernet operates at 125MHz clock over a twisted pair interface. In a typical system, the twisted-pair interface for each port consists of two differential signal pairs: one for the transmitter and one for the receiver, with the transmitter input

being the most sensitive to damage. The fatal discharge occurs differentially across the transmit or receive line pair and is capacitively coupled through the transformer to the Ethernet chip. Figure 8 shows how to design the TPD4E001DBVR on the line side of a 10/100 ethernet port to provide differential mode protection. The common mode isolation of the transformer will provide common mode protection to the rating of the transformer isolation which is usually >1.5kV. If more common mode protection is needed, figure 9 shows how to design the TPD4E001DBVR on the IC side of the 10/100.

## Applications Information (Continue)

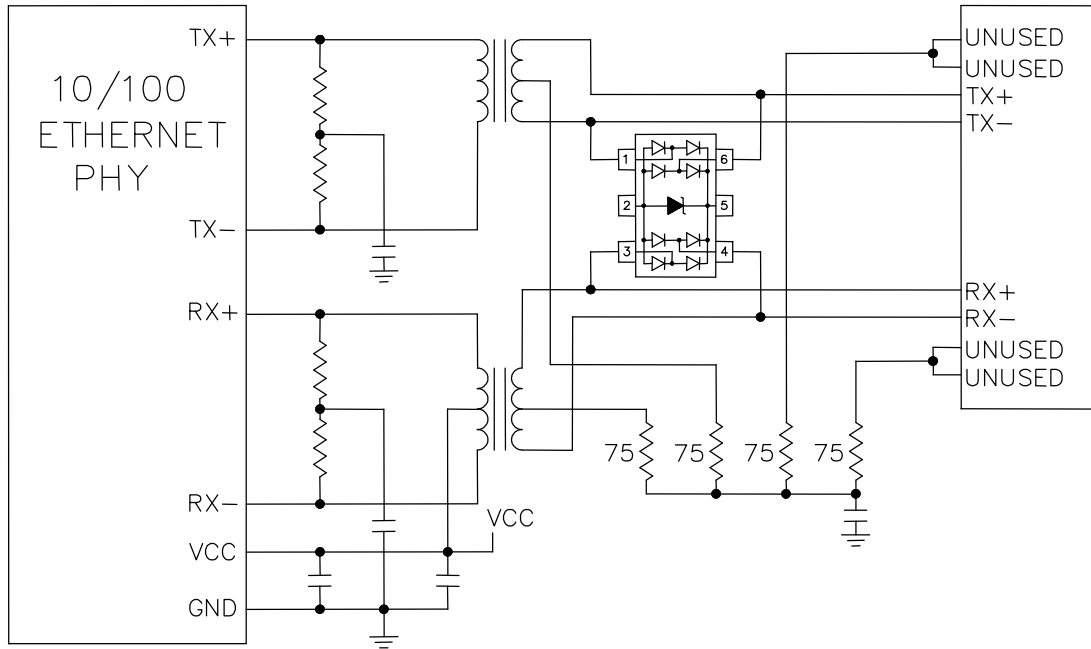

Figure 8 - 10/100 Ethernet Differential Protection

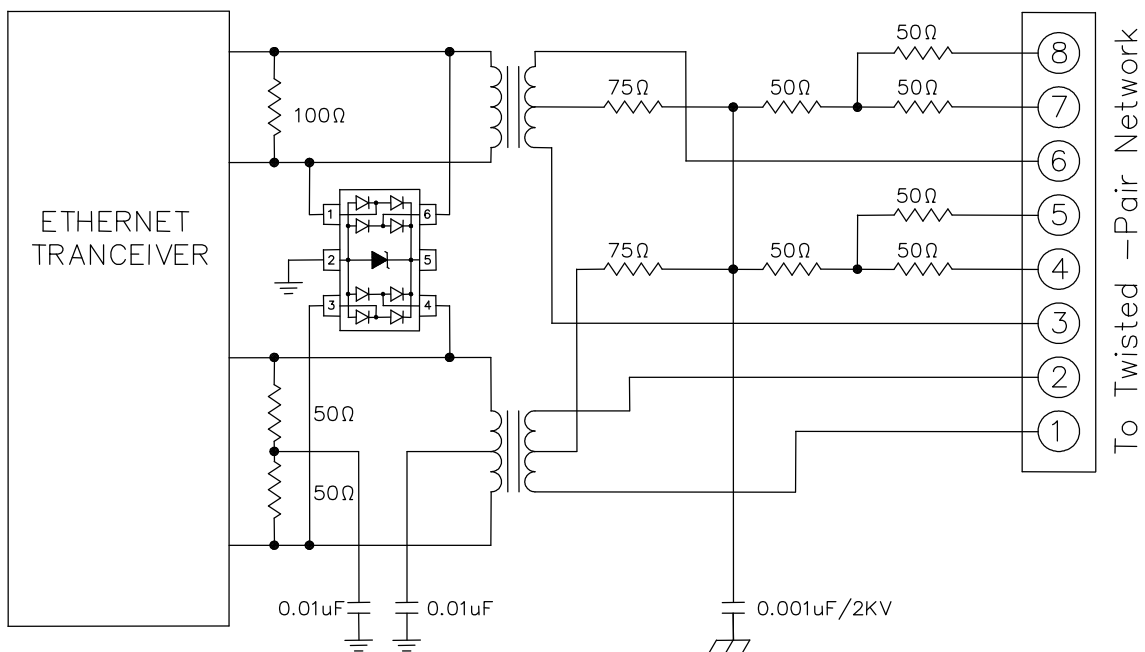
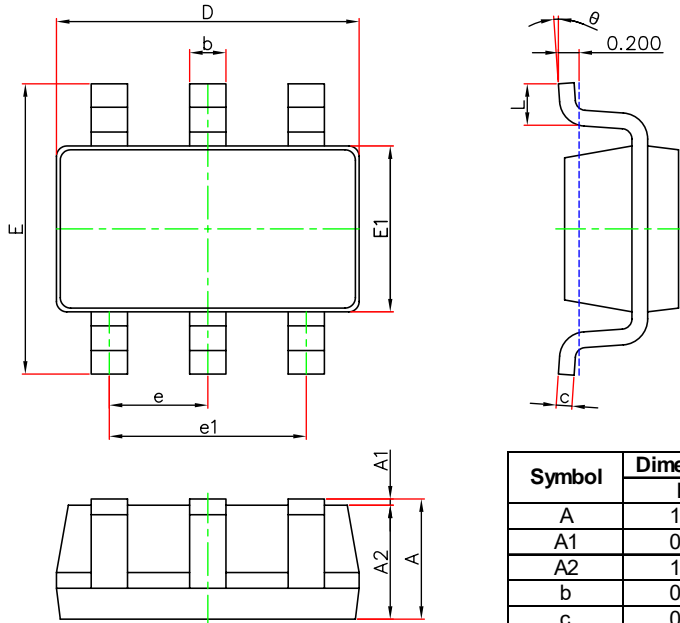

Figure 9 - 10/100 Ethernet Differential and Common Mode Protection

## SOT-26 Package Outline Drawing



| Symbol | Dimensions In Millimeters |       | Dimensions In Inches |       |
|--------|---------------------------|-------|----------------------|-------|
|        | Min.                      | Max.  | Min.                 | Max.  |
| A      | 1.050                     | 1.250 | 0.041                | 0.049 |
| A1     | 0.000                     | 0.100 | 0.000                | 0.004 |
| A2     | 1.050                     | 1.150 | 0.041                | 0.045 |
| b      | 0.300                     | 0.500 | 0.012                | 0.020 |
| c      | 0.100                     | 0.200 | 0.004                | 0.008 |
| D      | 2.820                     | 3.020 | 0.111                | 0.119 |
| E1     | 1.500                     | 1.700 | 0.059                | 0.067 |
| E      | 2.650                     | 2.950 | 0.104                | 0.116 |
| e      | 0.950(BSC)                |       | 0.037(BSC)           |       |
| e1     | 1.800                     | 2.000 | 0.071                | 0.079 |
| L      | 0.300                     | 0.600 | 0.012                | 0.024 |
| θ      | 0°                        | 8°    | 0°                   | 8°    |

## Suggested Land Pattern

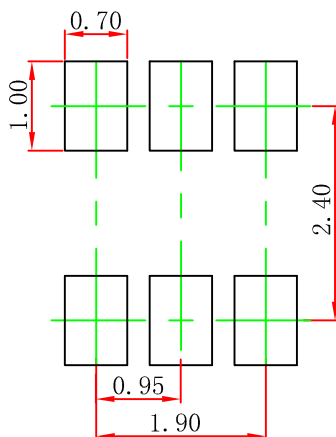

**Note:**

1. Controlling dimension: in millimeters.
2. General tolerance:  $\pm 0.05\text{mm}$ .
3. The pad layout is for reference purposes only.

### NOTICE

Leiditech reserves the right to make modifications, enhancements, improvements, corrections or other changes without further notice to any product herein. Leiditech does not assume any liability arising out of the application or use of any product described herein.