

Features

- Ultra low leakage: nA level
- Operating voltage: 5V
- Low clamping voltage
- Complies with following standards:
 - IEC 61000-4-2 (ESD) immunity test
 - Air discharge: $\pm 30\text{kV}$
 - Contact discharge: $\pm 30\text{kV}$
 - IEC61000-4-4 (EFT) 40A (5/50ns)
 - IEC61000-4-5 (Lightning) 12A (8/20 μs)
- RoHS Compliant

Dimensions SOT-26

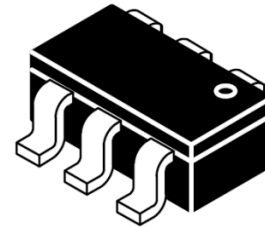

Applications

- USB 2.0 power and data line
- Monitors and flat panel displays
- Set-top box and digital TV
- Digital video interface (DVI)
- Notebook Computers
- SIM Ports
- 10/100 Ethernet
- IEEE 1394 firewire ports

Pin Configuration

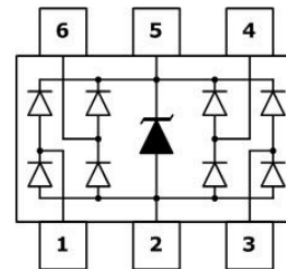

Mechanical Characteristics

- Package: SOT-26
- Lead Finish: Matte Tin
- UL Flammability Classification Rating 94V-0
- Quantity Per Reel: 3,000pcs
- Reel Size: 7inch
- Device Marking: SV05

Absolute Maximum Ratings (Tamb=25°C unless otherwise specified)

Parameter	Symbol	Value	Unit
Peak Pulse Power (8/20 μs)	Ppp	300	W
ESD per IEC 61000-4-2 (Air)	V _{ESD}	± 30	kV
ESD per IEC 61000-4-2 (Contact)		± 30	
Operating Temperature Range	T _J	-55 to +125	°C
Storage Temperature Range	T _{STJ}	-55 to +150	°C

Electrical Characteristics (TA=25°C unless otherwise specified)

Parameter	Symbol	Test Condition	Min	Typ	Max	Unit
Reverse Working Voltage	VRWM	Any I/O Pin to ground			5	V
Breakdown Voltage	VBR	IT = 1mA, any I/O Pin to ground	6			V
Reverse Leakage Current	IR	VRWM = 5V, any I/O Pin to ground			0.5	μA
Clamping Voltage	VC	I _{PP} = 1A (8 x 20μs pulse), any I/O pin to ground			15	V
Clamping Voltage	VC	I _{PP} = 12A (8 x 20μs pulse), any I/O pin to ground			25	V
Junction Capacitance	CJ	VR = 0V, f = 1MHz, between I/O pins		1.5		pF
Junction Capacitance	CJ	VR = 0V, f = 1MHz, any I/O pin to ground		3.0	5.0	pF

Note 1: I/O pins are Pin 1, 3, 4 and 6

Typical Performance Characteristics ($T_A=25^{\circ}\text{C}$ unless otherwise Specified)

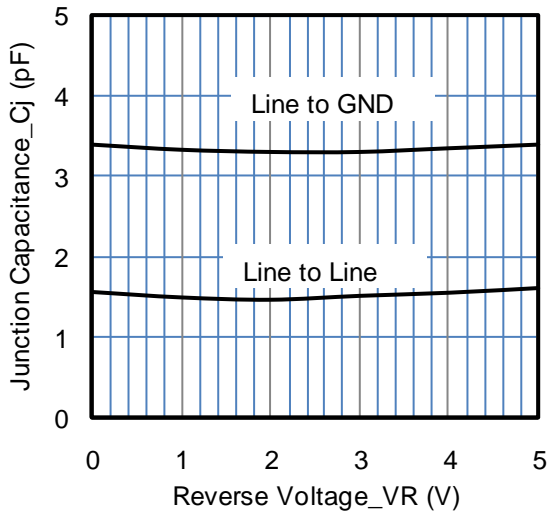

Junction Capacitance vs. Reverse Voltage

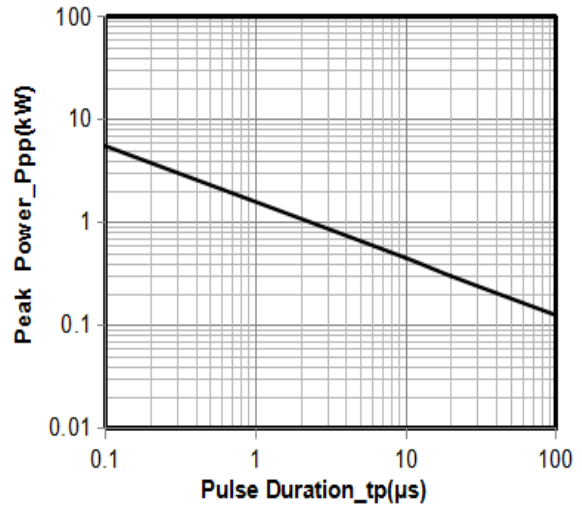

Peak Pulse Power vs. Pulse Time

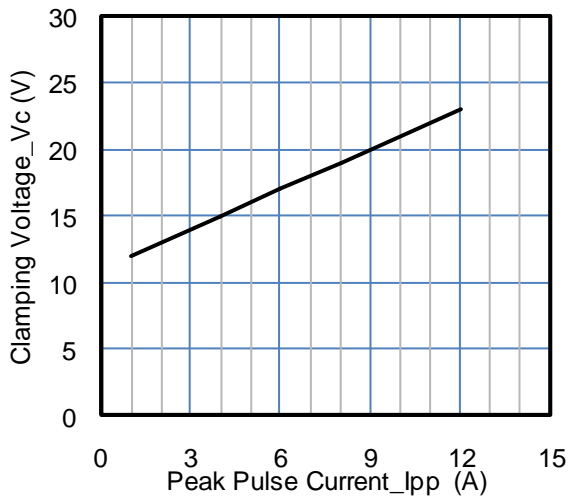

Clamping Voltage vs. Peak Pulse Current

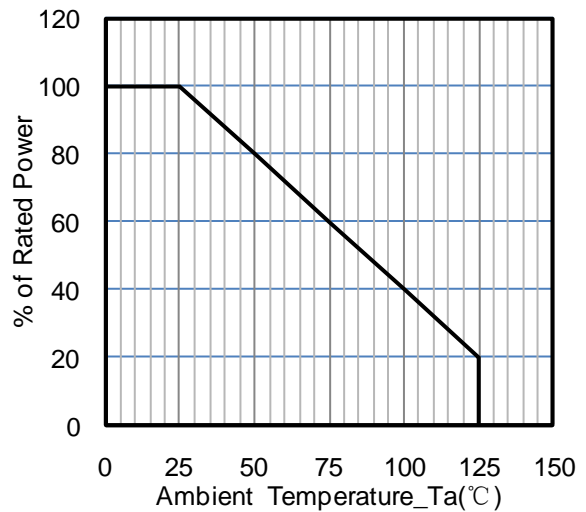

Power Derating Curve

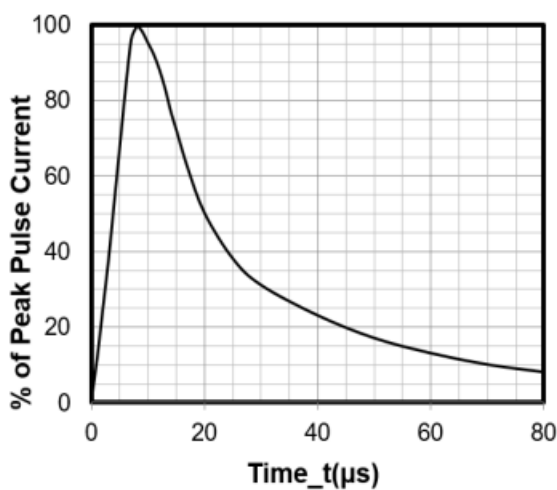

8 X 20 μs Pulse Waveform

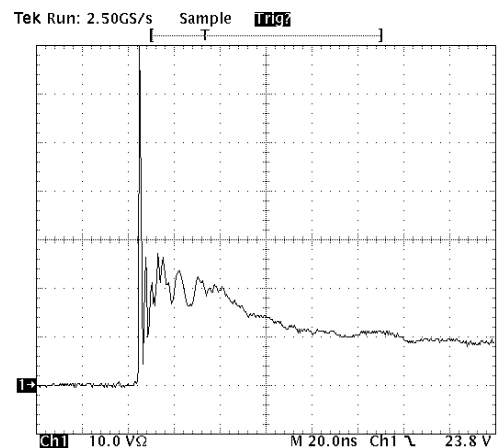

Note: Data is taken with a 10x attenuator

ESD Clamping Voltage

8 kV Contact per IEC61000-4-2

Typical Application

The SRV05-4W1 is designed to protect four data lines from transient over-voltages by clamping them to fixed reference. When the voltage on the protected line exceeds the reference voltage (plus diode VF) the steering diodes are forward biased, conducting the transient current away from the sensitive circuitry. Data lines are connected at pins 1, 3, 4 and 6. The negative reference (REF1) is connected at pin 2. This pin should be connected directly to a ground plane on the board for best results. The path length is kept as short as possible to minimize parasitic inductance. The positive reference (REF2) is connected at pin 5.

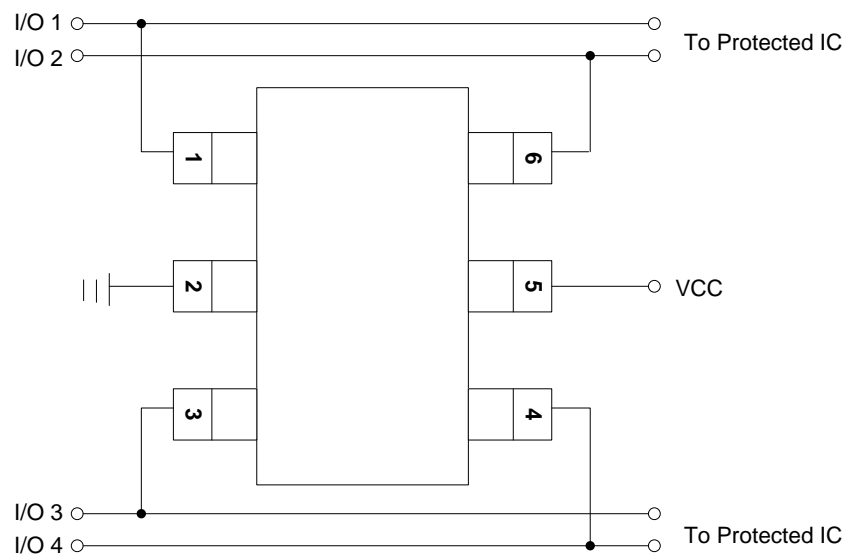

SRV05-4W1 on Video Interface Application

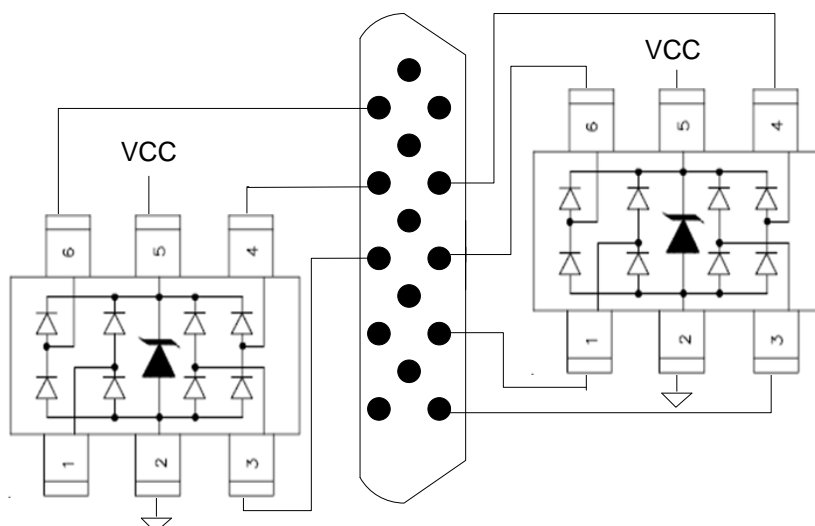

SRV05-4W1 on USB Port Application

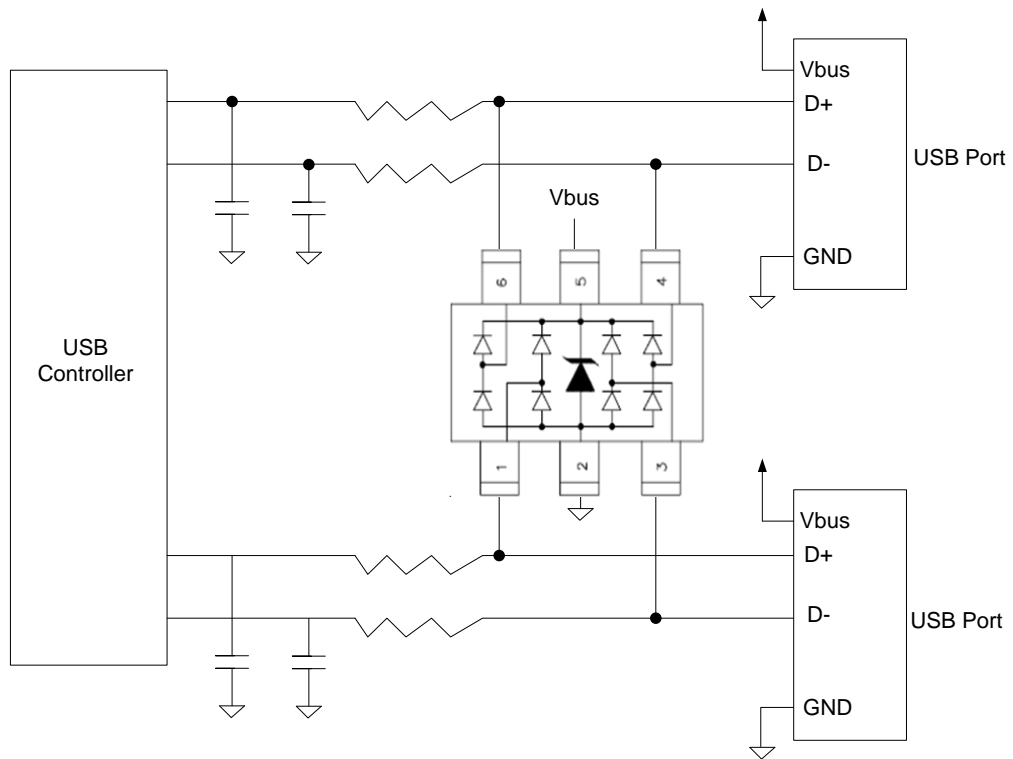

SRV05-4W1 on SIM Port Application

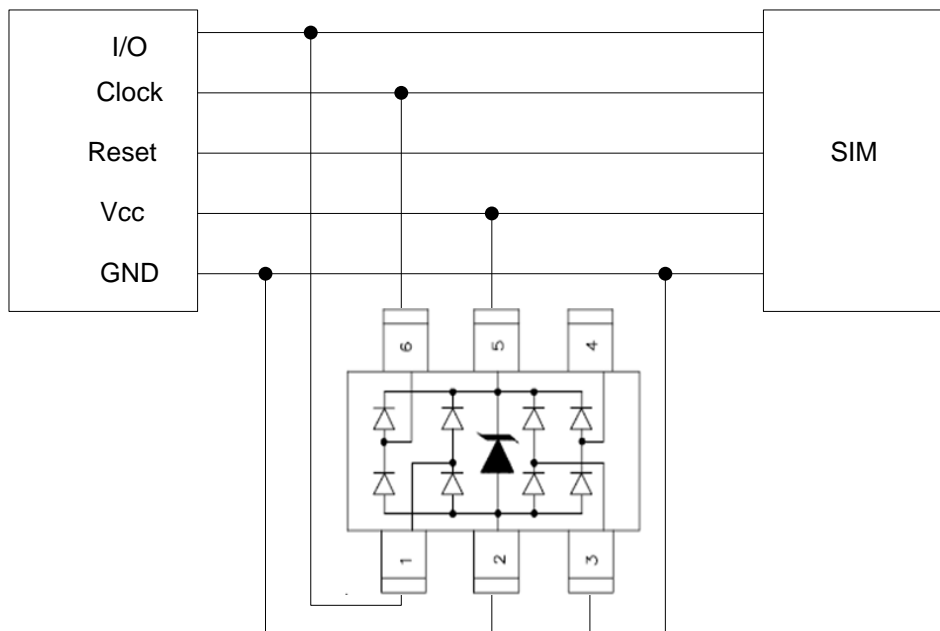

SRV05-4W1 on Digital Visual Interface (DVI) Application

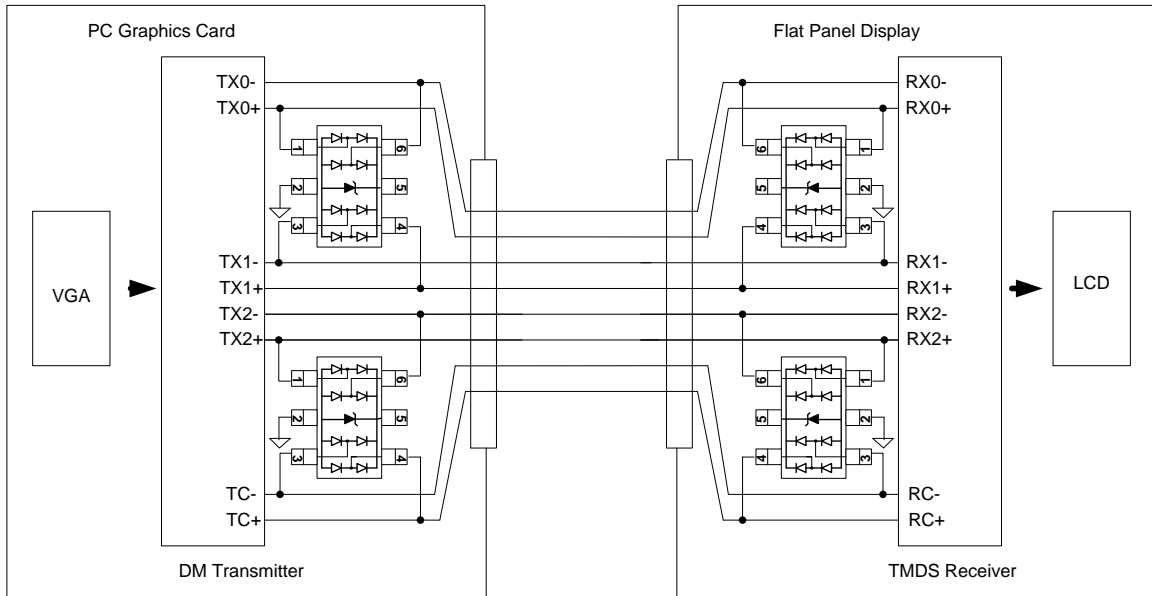

SRV05-4W1 on Ethernet 10/100 (Differential mode) Application

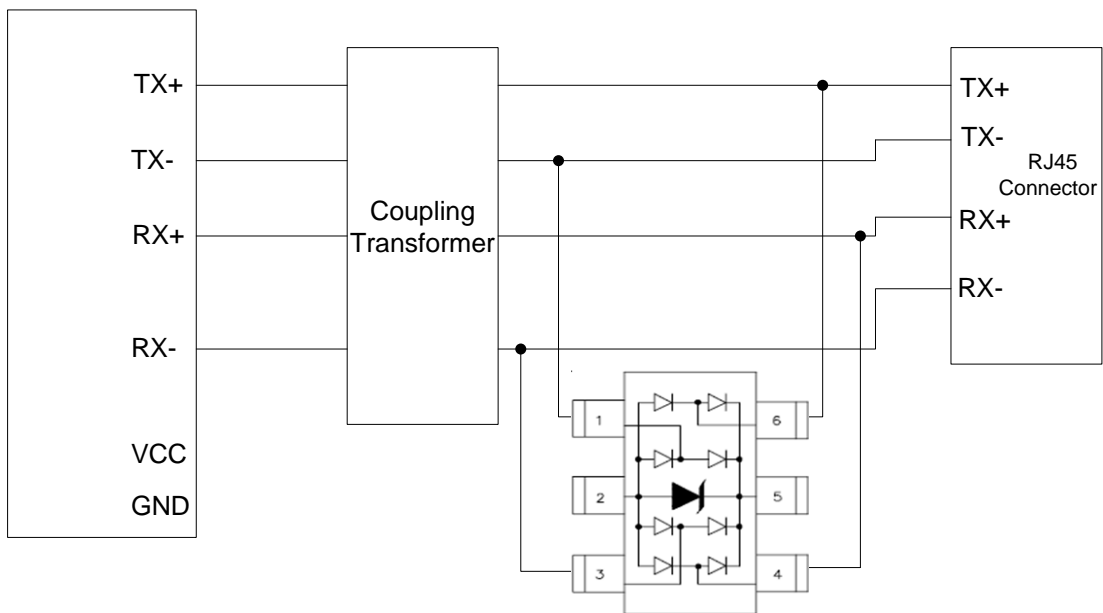

SRV05-4W1 on T1/E1 Interface Application

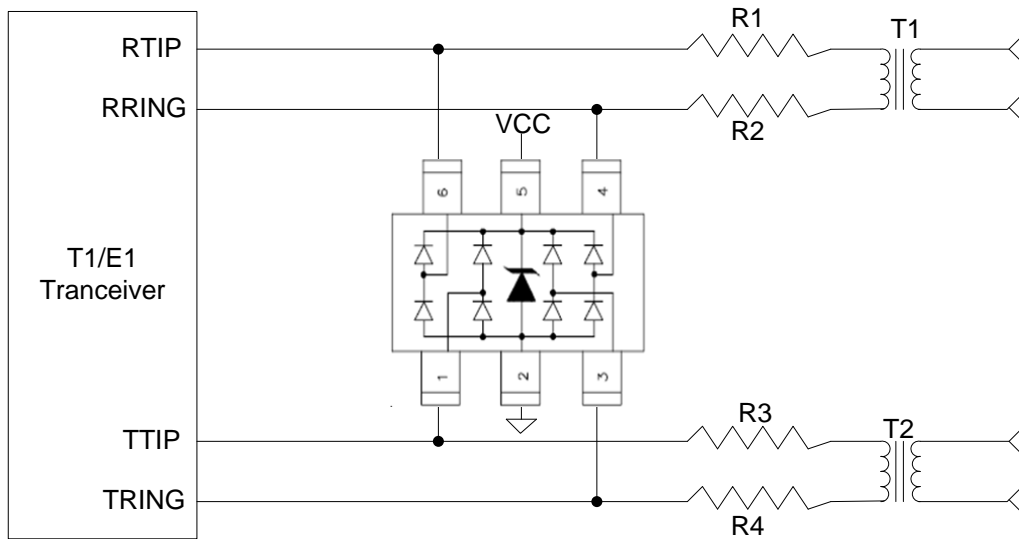

SOT-26 Package Outline Drawing

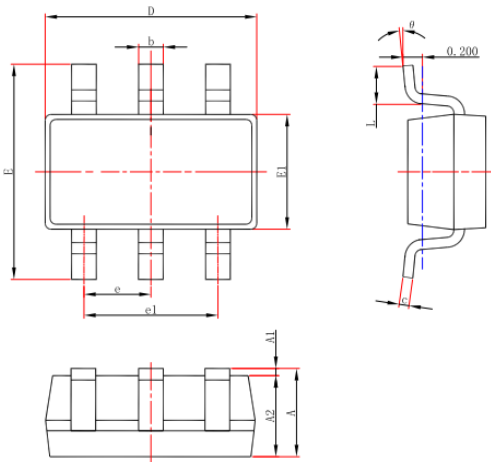

Symbol	Dimensions In Millimeters		Dimensions In Inches	
	Min.	Max.	Min.	Max.
A	1.050	1.250	0.041	0.049
A1	0.000	0.100	0.000	0.004
A2	1.050	1.150	0.041	0.045
b	0.300	0.500	0.012	0.020
c	0.100	0.200	0.004	0.008
D	2.820	3.020	0.111	0.119
E1	1.500	1.700	0.059	0.067
E	2.650	2.950	0.104	0.116
e	0.950(BSC)		0.037(BSC)	
e1	1.800	2.000	0.071	0.079
L	0.300	0.600	0.012	0.024
θ	0°	8°	0°	8°

Suggested Land Pattern

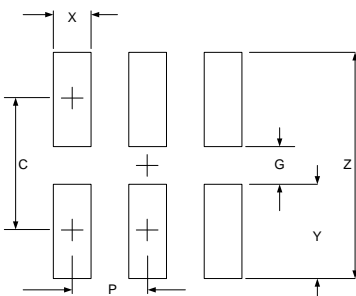

SYM	DIMENSIONS	
	MILLIMETERS	INCHES
C	2.50	0.098
G	1.40	0.055
P	0.95	0.037
X	0.60	0.024
Y	1.10	0.043
Z	3.60	0.141

NOTICE

Leiditech reserves the right to make modifications, enhancements, improvements, corrections or other changes without further notice to any product herein. Leiditech does not assume any liability arising out of the application or use of any product described herein.

Shanghai Leiditech Electronic Technology Co., Ltd.

Email: sale1@leiditech.com

Tel : +86- 021 50828806

Fax : +86- 021 50477059